

SYSTEMATIC INSPECTION PROCEDURE FOR THE 2½ TON TRUCK

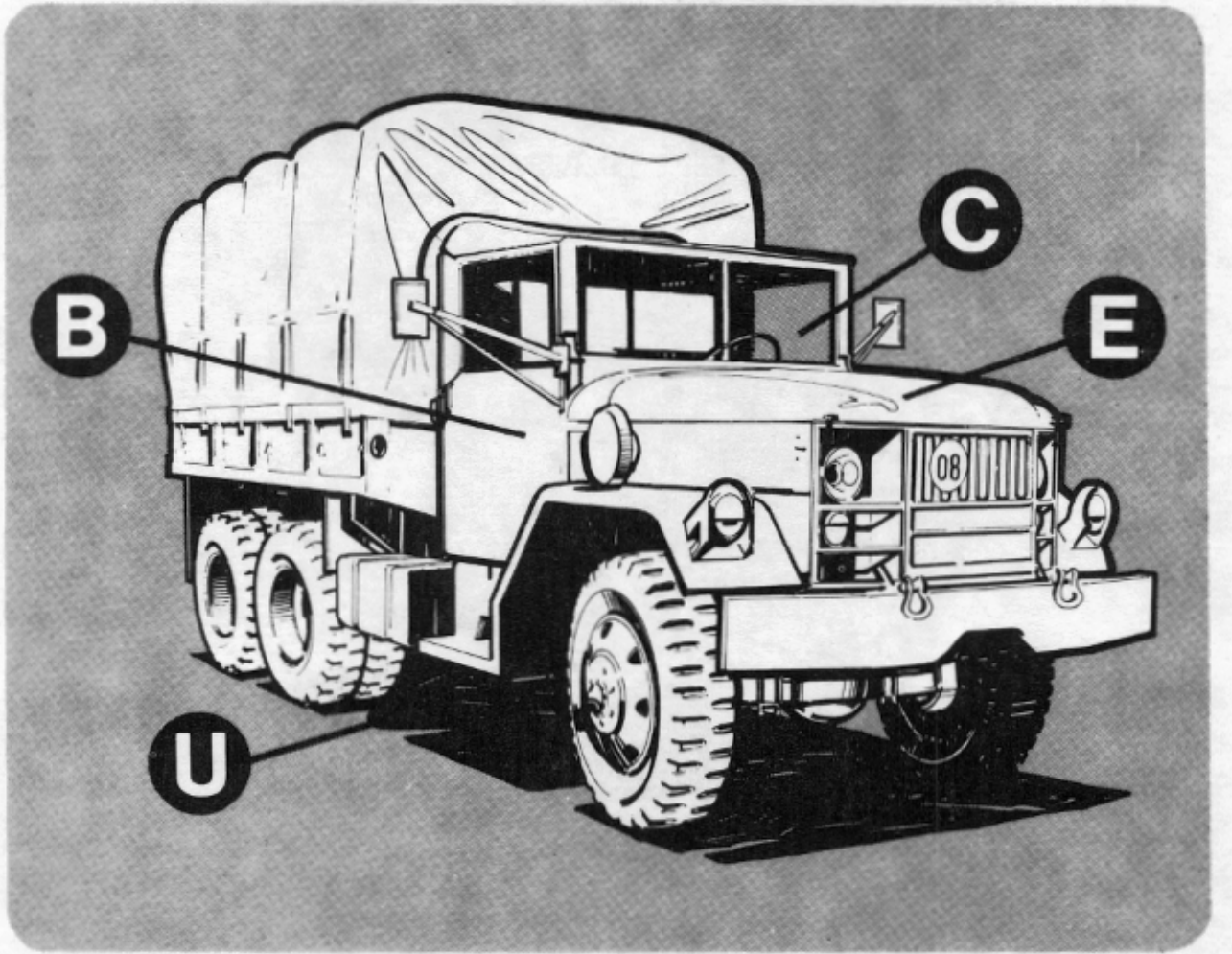

This checklist provides a systematic procedure for inspecting the 2½ ton truck. It should be used with DA Form 2404—The Maintenance & Inspection Worksheet. Defects which cannot be corrected by the vehicle operator should be noted on DA Form 2404 which, when completed, should be turned over to the Maintenance Supervisor or his representative. This systematic inspection procedure will benefit you when inspecting other similar vehicles.

NOTE: This systematic Inspection Procedure is to be used in conjunction with TEC Lessons 944-091-0002-F thru 0005-F. No inspection should begin until handbrake is engaged, transmission placed in neutral and chock blocks placed to the front and rear of at least one wheel.

OCTOBER 1977

GTA 09-01-185 (1-8)

E

ENGINE INSPECTION | DRIVER'S SIDE

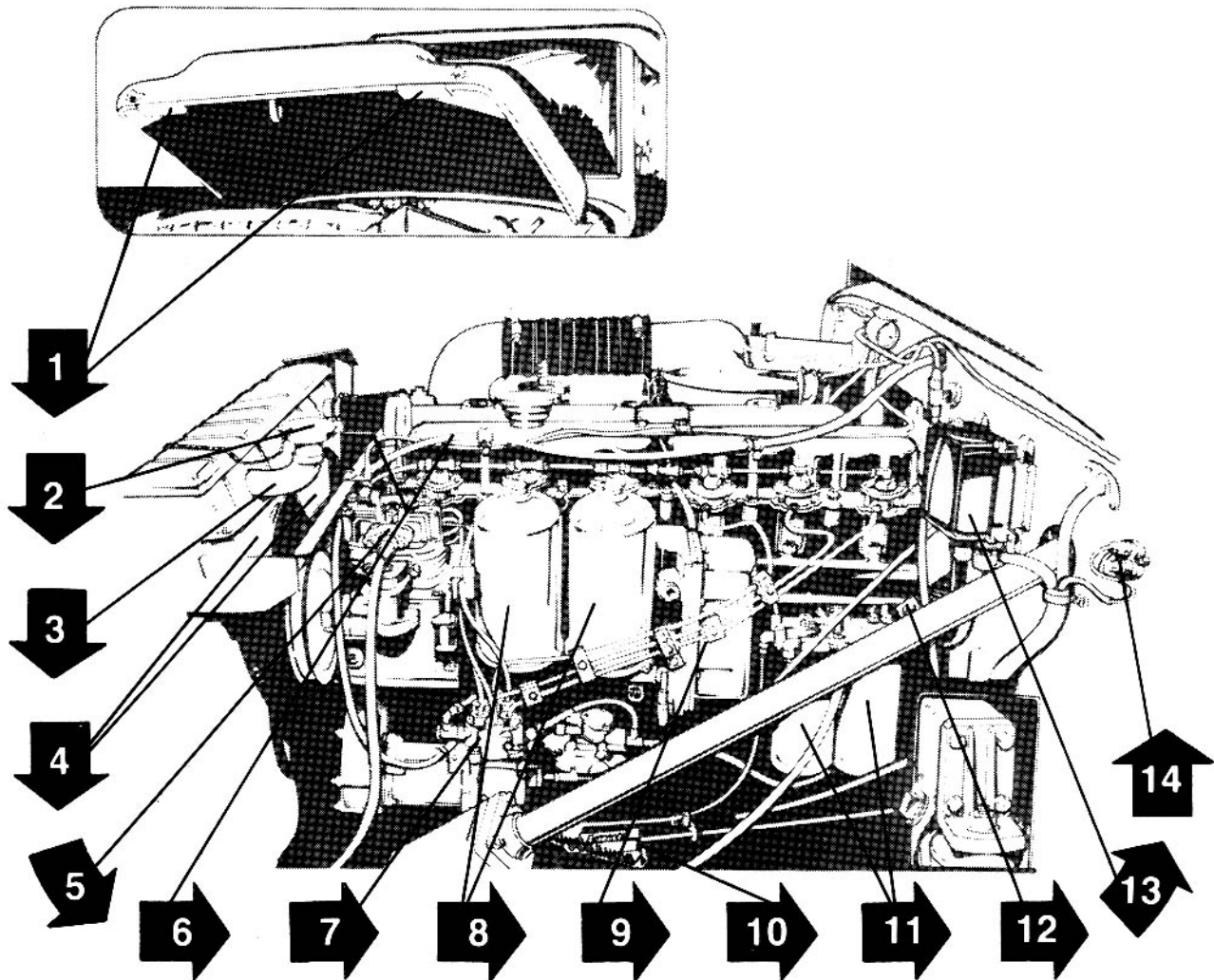

This Systematic Inspection Procedure is designed to make it easier for you to inspect and check your 2½ ton truck to help keep it "always ready" to move. Simply follow the direction of the arrows as you make your inspection.

1. CHECK ANTI-VIBRATION BUMPERS (2) attached to front under side of the hood, see if they are in good condition.
2. CHECK RADIATOR CAP, it should have a good gasket and should be attached to a safety chain.
3. CHECK COOLANT LEVEL IN RADIATOR, wait until it's cool, approx. 30 minutes, then remove cap and check coolant level. Add coolant if not visible in filler until you can see it.
4. CHECK RADIATOR, FAN & FAN SHROUD for tightness and any damage or leaks. Clean core if clogged with bugs or leaves.
5. CHECK AIR COMPRESSOR & AIR LINES. Make sure they are securely mounted and there are no leaks.
6. CHECK AIR COMPRESSOR GOVERNOR LINE, see that it is in good condition. Also check the flexible shaft.
7. CHECK FUEL INJECTION PUMP, see that it is securely mounted and shows no signs of leaks.
8. CHECK ENGINE OIL FILTERS, see that they are properly mounted and not leaking.
9. CHECK ENGINE OIL COOLER, see that it is mounted securely and not leaking.
10. CHECK ACCELERATOR LINKAGE, make sure all connections are secure and return spring is in place.
11. CHECK FUEL FILTERS, try wiggling them to make sure they are securely mounted. Examine the fuel lines for leaks, inspect flexible line for cracks, holes or signs of leakage.
12. CHECK GROUND STRAP bolts for tightness.
13. CHECK GENERATOR REGULATOR, see that it is mounted securely, cover on tight and cables on bottom are properly connected not frayed or broken.
14. CHECK CIRCUIT BREAKER, see that it is securely mounted and wires are in serviceable condition.

E ENGINE INSPECTION | PASSENGER'S SIDE

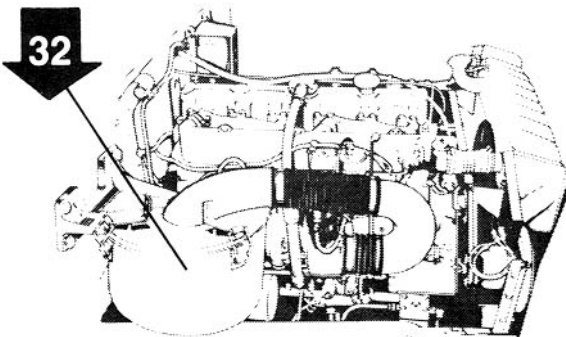
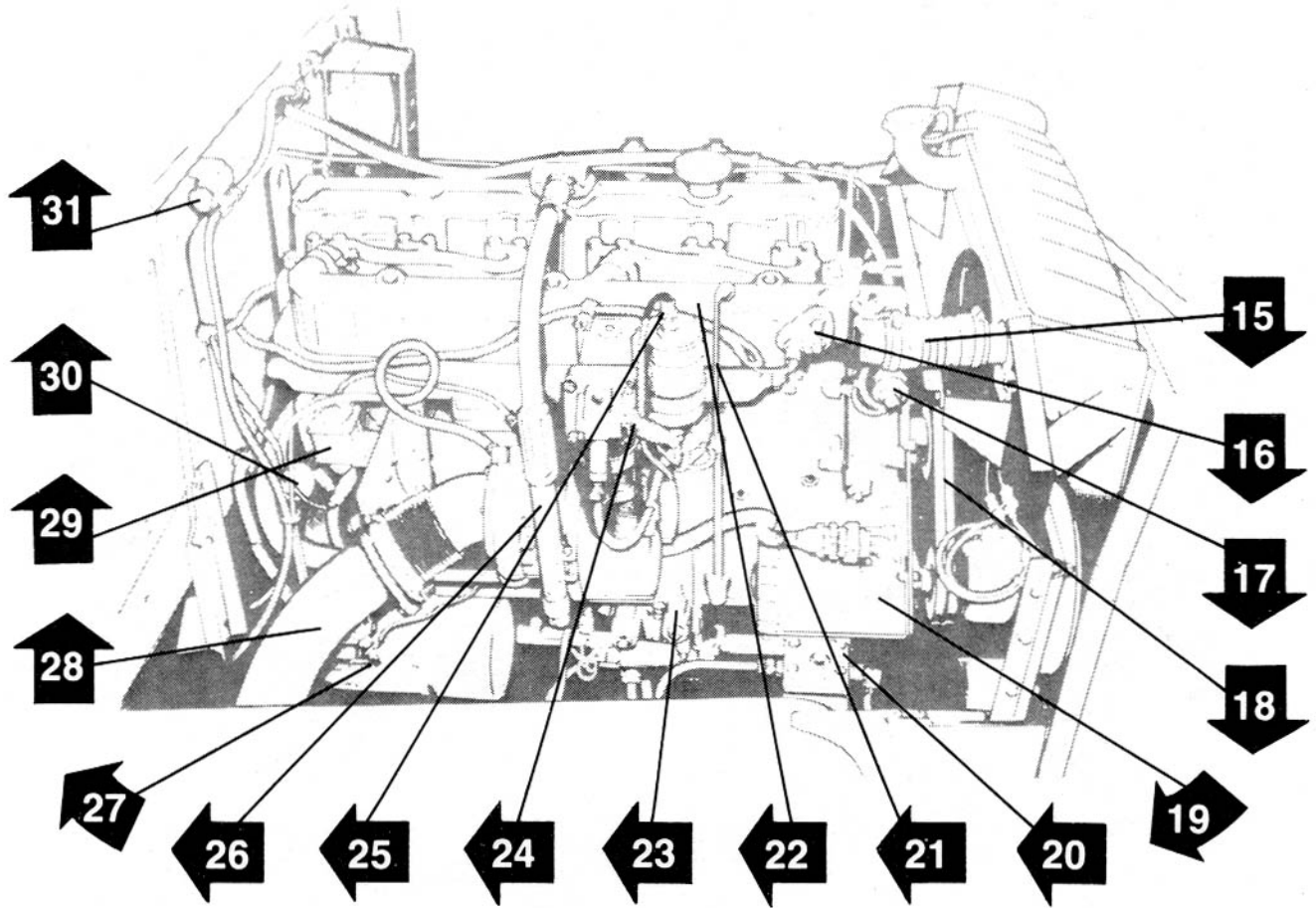

- 15. CHECK TOP WATER HOSE, see if it's in good condition.
- 16. CHECK TEMPERATURE SENDING UNIT, see that it does not leak, lead is connected properly and that clip is fastened to manifold.
- 17. CHECK WATER PUMP for leaks and cracks.
- 18. CHECK V-BELTS for proper adjustment and condition.
- 19. CHECK GENERATOR, make sure mounting bolts are tight.
- 20. CHECK PRIMARY FUEL FILTER, insure it is mounted securely and not leaking.
- 21. CHECK OIL LEVEL, remove dipstick and check.
- 22. CHECK AIR INTAKE MANIFOLD for tightness and cracks.

- 23. CHECK FUEL SUPPLY PUMP. It should be mounted securely, fuel line connections tight and no leaks.
- 24. CHECK MANIFOLD HEATER, see that it is mounted securely.
- 25. CHECK ELECTRICAL COIL, see that it is securely mounted and the electrical connections are finger tight.
- 26. CHECK CRANKCASE BREATHER TUBE, see that it is securely mounted, not damaged or bent.
- 27. CHECK STARTER MOTOR. make sure it is securely mounted and electrical connections are tight and in good condition.
- 28. CHECK EXHAUST PIPE CONNECTIONS for carbon streaks indicating an exhaust leak.
- 29. CHECK STARTER RELAY SWITCH to see if it is mounted securely and the cable connections are tight.
- 30. CHECK OIL PRESSURE SENDING UNIT for leaks, and condition of electrical connections.
- 31. CHECK AIR GOVERNOR, see that it is securely mounted and the air lines are not leaking.
- 32. CHECK AIR CLEANER. see that filter in canister is not dirty.

C CAB INSPECTION

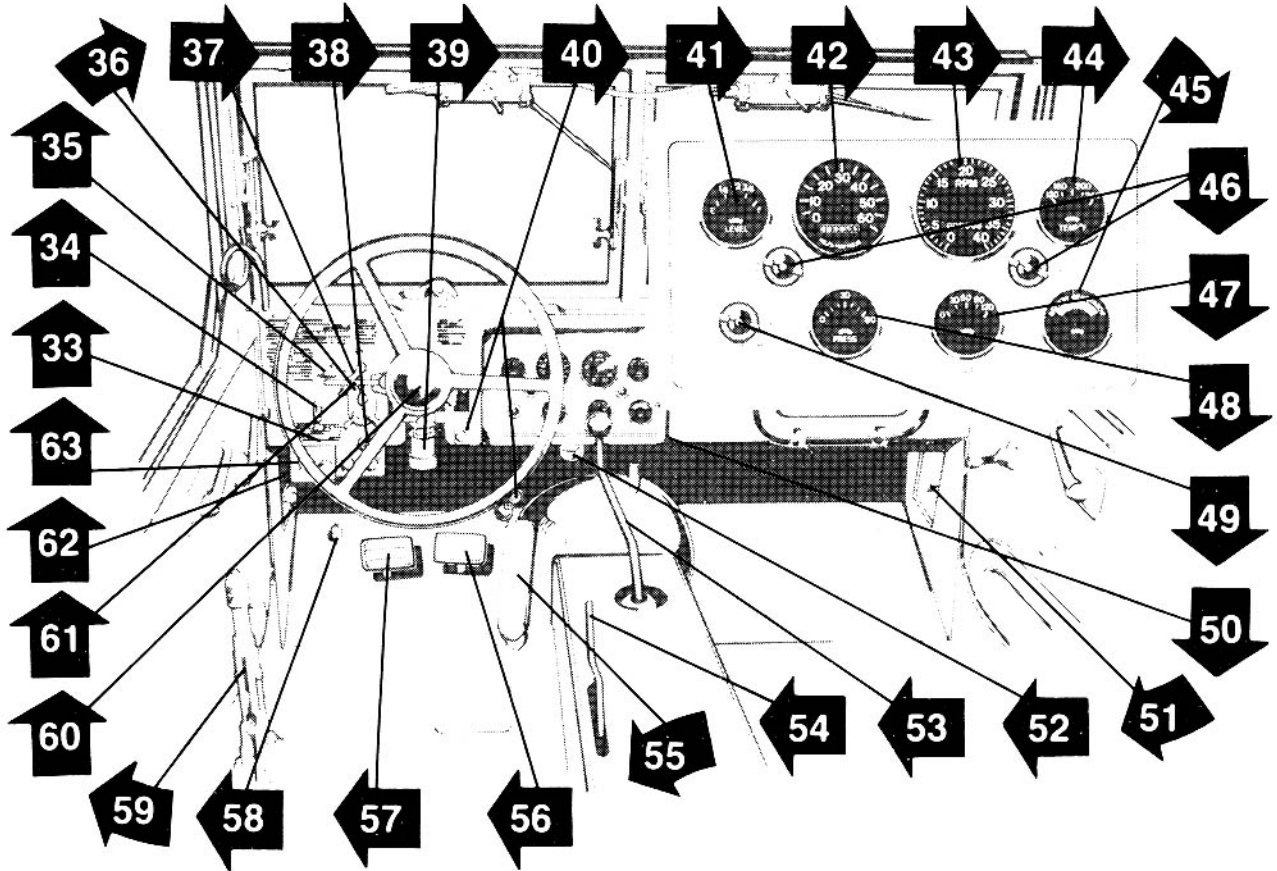

- | | |
|---|--|
| <p>33. CHECK MANIFOLD HEATER SWITCH, see that it is functioning properly and not damaged.</p> <p>34. CHECK HAND THROTTLE, extend it to the out position, release it by turning knob.</p> <p>35. CHECK ENGINE STOP, to see if it functions properly.</p> <p>36. CHECK LIGHT SWITCH, see if it functions properly in all positions.</p> <p>37. CHECK ACCESSORY SWITCH, turn it on to see if gages become activated.</p> <p>38. CHECK WINDSHIELD WIPER CONTROL KNOB, to see if it functions properly. In case of air failure the wipers can be operated by hand. Turn counterclockwise for "ON" position.</p> <p>39. CHECK AIR FILTER INDICATOR to see that it is not damaged. If dirty, a red flag will show. Clean filter if clogged and reset indicator.</p> <p>40. CHECK STARTER BUTTON, see that it is functional.</p> <p>41. CHECK FUEL GAGE, it should move to the right showing fuel level.</p> <p>42. CHECK SPEEDOMETER GAGE for damage and operation.</p> <p>43. CHECK TACHOMETER GAGE for damage and proper operation.</p> <p>44. CHECK TEMPERATURE GAGE for damage, see also that it functions properly.</p> <p>45. CHECK BATTERY-GENERATOR GAGE, needle should be in highside of yellow area.</p> <p>46. CHECK DASH LIGHTS, see that they function. Screw caps off to check.</p> <p>47. CHECK AIR PRESSURE GAGE. It should show approximately 105 lbs. of pressure after engine has been started and air pressure has built up.</p> | <p>48. CHECK OIL PRESSURE GAGE, it should show at least 15 lbs. of pressure 20 secs. after starting engine.</p> <p>49. CHECK HIGH BEAM INDICATOR, see that it is functioning properly. Service light switch must be on to check indicator lamp.</p> <p>50. CHECK HEATER & DEFROSTER DUCTING, Insure all ducting is connected properly and is in serviceable condition.</p> <p>51. CHECK AIR VENT (Passengers side) see if it opens and closes easily and is free of debris</p> <p>52. CHECK FRONT WHEEL DRIVE SWITCH to see that it is functioning properly.</p> <p>53. CHECK GEAR SHIFT LEVER to see if it moves into each position easily. First make sure hand brake is engaged.</p> <p>54. CHECK TRANSFER LEVER to see if functional.</p> <p>55. CHECK ACCELERATOR PEDAL.</p> <p>56. CHECK BRAKE PEDAL, there should be ¼" free travel, it should not feel spongy.</p> <p>57. CHECK CLUTCH PEDAL, there should be 1½" -2" free travel.</p> <p>58. CHECK DIMMER SWITCH to see if functional.</p> <p>59. CHECK HANDBRAKE. Should keep vehicle stationary when applied.</p> <p>60. CHECK HORN.</p> <p>61. CHECK DIRECTIONAL SIGNAL MECHANISM. see if it is functioning properly.</p> <p>62. CHECK AIR VENT (Driver's side) see if it opens and closes easily and is free of debris.</p> <p>63. CHECK PERSONNEL HEATER CONTROLS, see if they are functioning properly. Read instructions carefully. All vehicles are not equipped with a personnel heater.</p> |
|---|--|

NOTE: Accessory switch must be on to activate some instrument panel gages. Light switch must be on to check high beam indicator and dash lights. Starter button may be located in either location shown in diagram above.

B

BODY INSPECTION | FRONT & PASSENGER SIDE

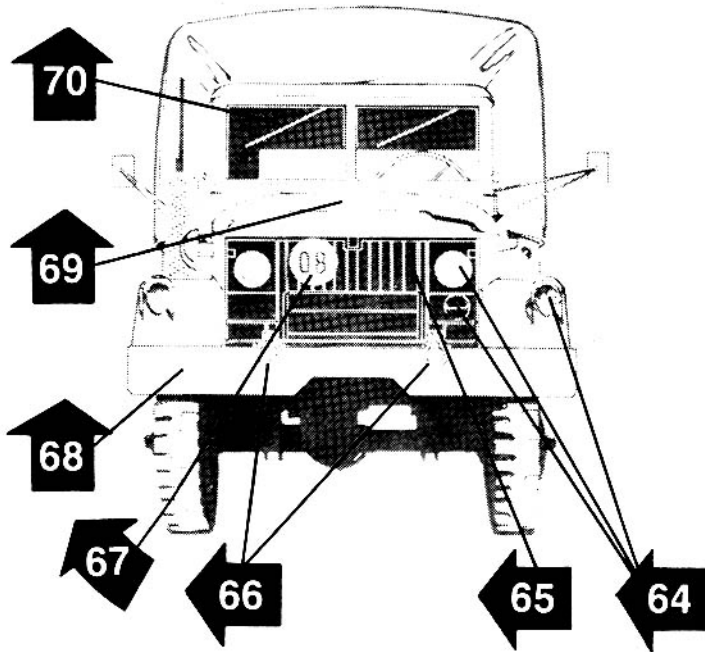

- 64. CHECK HEADLIGHTS, BLACKOUT LIGHTS & MARKER LIGHTS on both sides, see that the glass is not fogged or cracked and that lights function properly.
- 65. CHECK BRUSH GUARD, see that it is secure and not damaged.
- 66. CHECK LIFTING SHACKLES. They should move up and down freely and have a locking pin in each shackle.
- 67. CHECK BRIDGE WEIGHT MARKERS fastened on brush guard.
- 68. CHECK BUMPER, see if it is tight. It should not have any free movement or damage.
- 69. CHECK HOOD, see that it is held snugly by the latches, there should be no free movement, Also check the retaining latches that hold up the hood in its upright position. These are located on top of the hood.
- 70. CHECK WINDSHIELD & WIPERS for cracks, damage and serviceability.

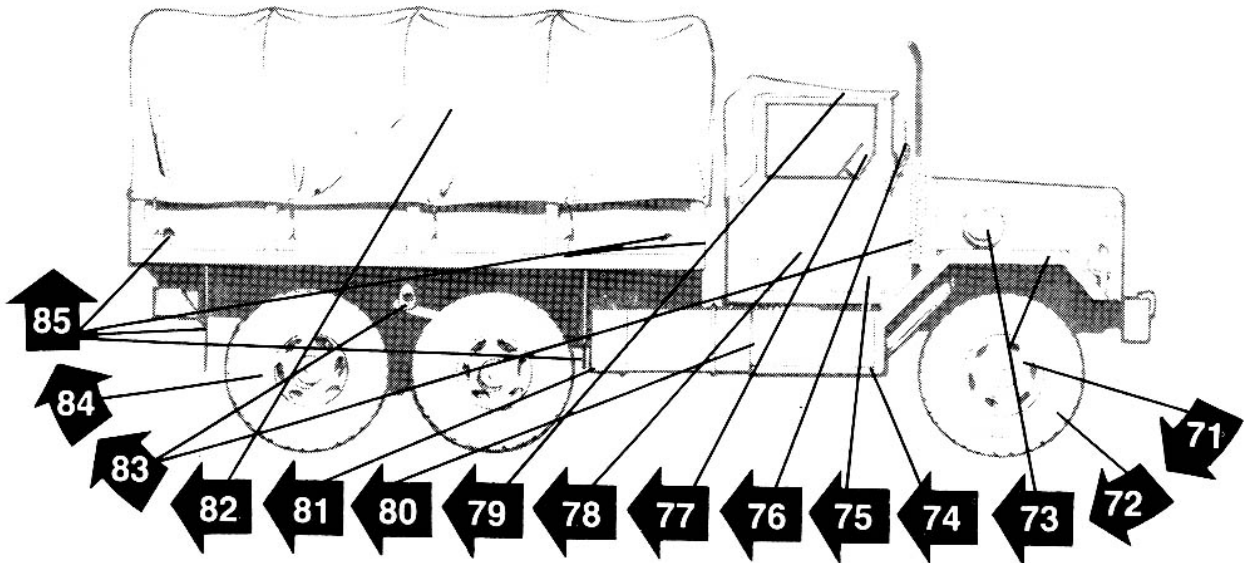

- | | | |
|--|---|--|
| <ul style="list-style-type: none">71. CHECK FRONT WHEEL, use a lug wrench to check tightness of wheel nuts.72. CHECK TIRE for cuts, bruises, blisters.73. CHECK AIR BONNET & FENDER, see that they are tight and secure.74. CHECK FENDER & RUNNING BOARD for tightness and damage.75. CHECK CAB DOOR (Passenger's side) see that it is tight, its hinges securely mounted and that the door swings freely and that the door stop is not damaged. | <ul style="list-style-type: none">76. CHECK OUTSIDE MIRROR, to see if it is mounted securely, is in good condition, not cracked or cloudy.77. CHECK WINDOW, see that it rolls up and down easily and is not cracked.78. CHECK PASSENGER SEAT for rips, tears, holes or damage.79. CHECK CANVAS TOP for rips or holes.80. CHECK BATTERY COMPARTMENT. see if cables are tight on terminals and electrolyte level is proper. | <ul style="list-style-type: none">81. CHECK FUEL TANK, check fuel strainer for dirt.82. CHECK BODY CANVAS TOP for rips, holes and proper lashing.83. CHECK TAIL PIPE for secure mounting. On some models there is an exhaust stack.84. CHECK REAR TIRES, see that hub bolts and wheel nuts are tight and that none are missing. Check tire for cuts, bruises or blisters.85. CHECK SIDE REFLECTORS, MUD-GUARDS, BRACES & FLAPS. See that they are not damaged. |
|--|---|--|

B BODY INSPECTION | REAR & DRIVER'S SIDE

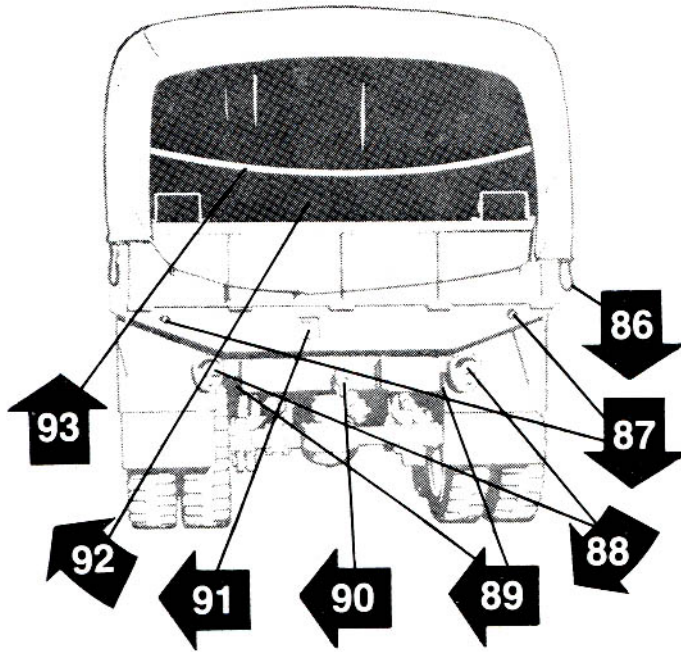

- 86. CHECK TAILGATE CHAIN, it must be covered with rubber or canvas.
- 87. CHECK REAR REFLECTORS, see that they are in good condition.
- 88. CHECK TAIL LIGHTS & BLACK OUT LIGHTS, see that they are not fogged, that the lenses are not broken and that they function properly.
- 89. CHECK AIR HOSE CONNECTORS for damage. Insure that rubber gaskets are serviceable.
- 90. CHECK TOWING PINTLE, it should swivel freely and have a locking pin on a chain.
- 91. CHECK TRAILER POWER OUTLET, see that the cover is held securely by a spring and that it's in good condition. The outlet should be free of dirt and corrosion.
- 92. CHECK WOODEN SIDE RAILS & BOWS that they are not broken or split. Check also the front rack locking pins to see if attached to security chain.
- 93. CHECK TROOP SAFETY STRAP for signs of wear or damage.

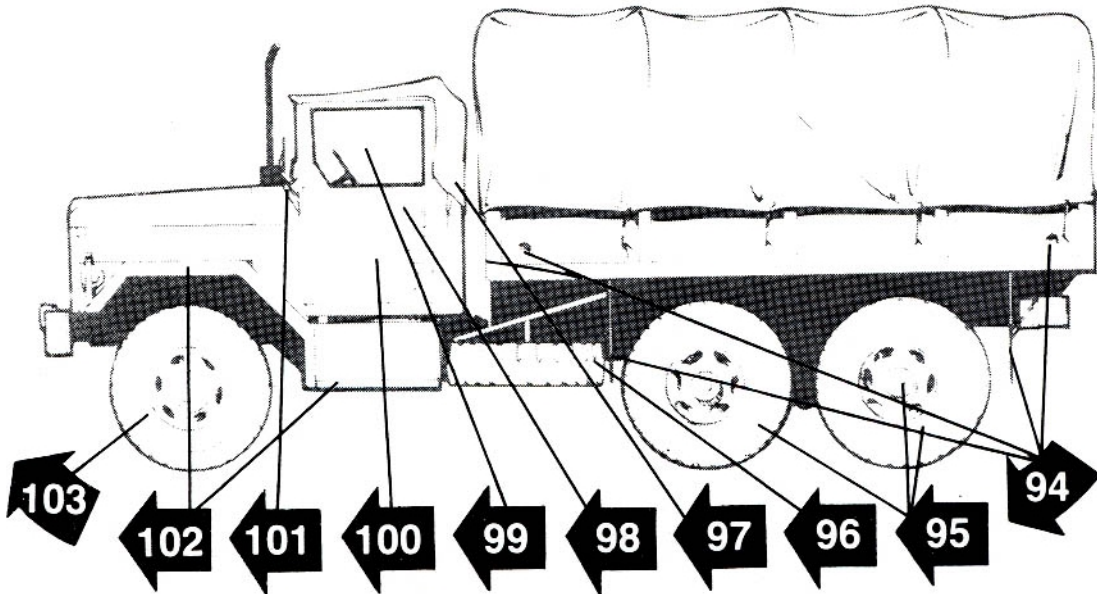

- | | | |
|---|--|---|
| <ul style="list-style-type: none"> 94. CHECK DRIVER'S SIDE REFLECTORS, MUD GUARDS & FLAPS that all are in good condition. 95. CHECK TIRES, see that hub screws and wheel nuts are tight and that none are missing. Check tires for cuts, bruises or blisters. 96. CHECK SPARE WHEEL, see that it is mounted properly and securely. | <ul style="list-style-type: none"> 97. CHECK LASHING ROPE, it should be under each hook and knotted securely. 98. CHECK CAB DOOR (Driver's side) see that it is tight, its hinges securely mounted and that the door swings freely and that the door stop is not damaged. 99. CHECK WINDOW to see that it rolls up and down easily and that it is not cracked. 100. CHECK SEAT (Driver's side) for rips, tears, holes or damage. | <ul style="list-style-type: none"> 101. CHECK OUTSIDE MIRROR to see if it is mounted securely, is in good condition not cracked or cloudy. 102. CHECK FENDER & RUNNING BOARD, for tightness and damage. 103. CHECK FRONT TIRE, see that hub screws and wheel nuts are tight and that none are missing. Check tire for cuts, bruises or blisters. |
|---|--|---|

NOTE: After complete body inspection has been made, all tires should be checked for proper inflation.

U UNDERNEATH INSPECTION

FRONT

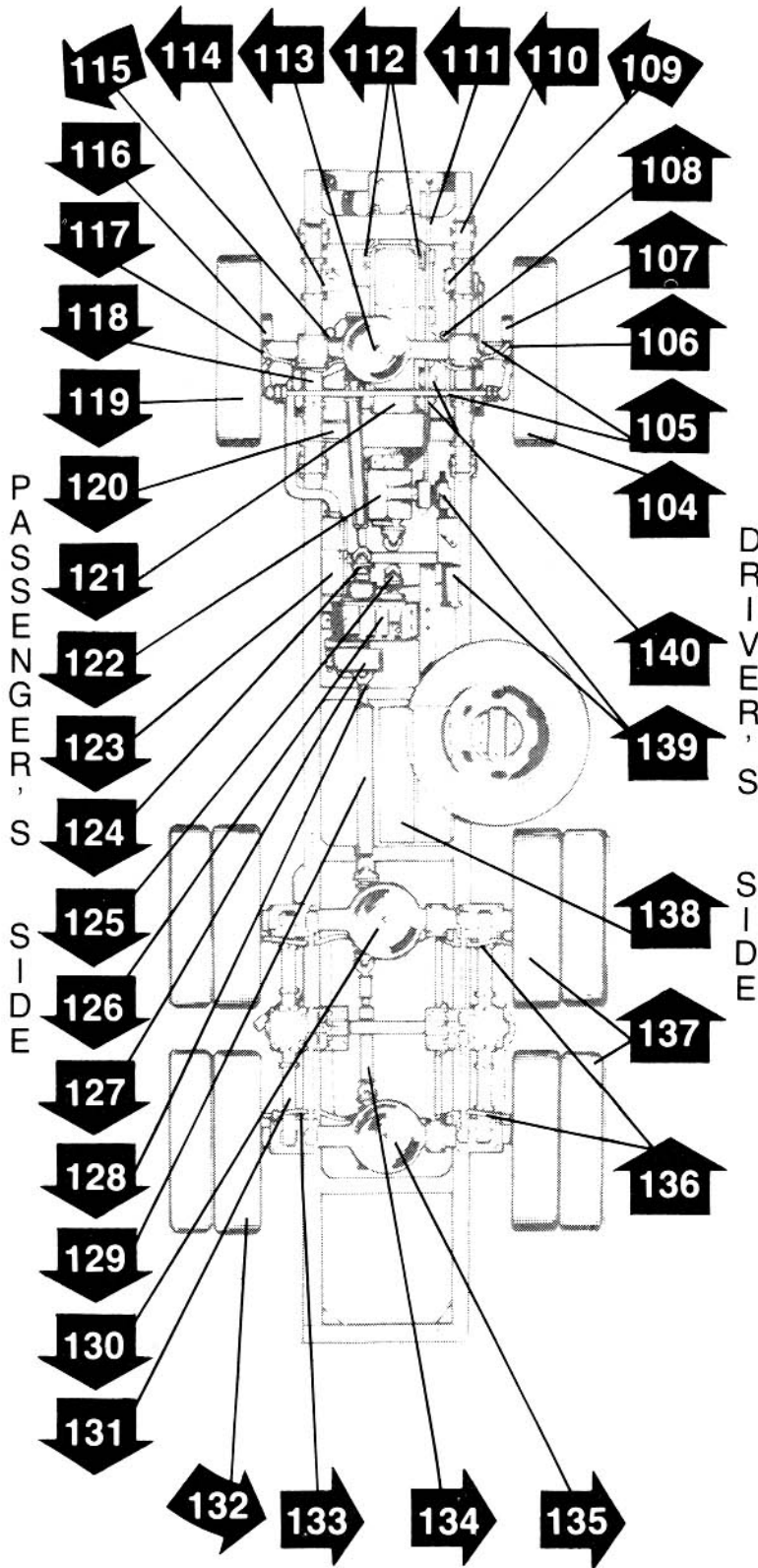

(BOTTOM VIEW)

104. CHECK FRONT TIRE (Drivers side) for cuts, bruises or blisters.
105. CHECK STEERING TIE ROD& DRAG LINK to see that they are not loose or bent.
106. CHECK HYDRAULIC BRAKE line for leaks or damage.
107. CHECK CV BOOT for proper mounting, leaks, tears or cracks.
108. CHECK SHOCK ABSORBER for damage, leaks and mounting.
109. CHECK STEERING COLUMN GEAR BOX, see that the bolts are tight.
110. CHECK FRONT SPRING (Driver's side) for cracked leaves and secure mounting.
111. CHECK WINCH DRIVE SHAFT. (For vehicles equipped with winch.)
112. CHECK ENGINE MOUNT, make sure bolts are securely in place.
113. CHECK DIFFERENTIAL, be sure there are no leaks.
114. CHECK PRIMARY FUEL FILTER by draining some fuel in a container and checking it for water or dirt.
115. CHECK SHOCK ABSORBER for damage, leaks and mounting.
116. CHECK CV BOOT for proper mounting, leaks, tears or cracks.
117. CHECK HYDRAULIC BRAKE LINE for leaks or damage.
118. CHECK FRONT SPRING (Passengers side) for cracked leaves and secure mounting.
119. CHECK FRONT TIRE (Passenger's side) for cuts, bruises or blisters.
120. CHECK ENGINE MOUNT, make sure bolts are securely in place, (Driver's and Passenger's sides).
121. CHECK ENGINE CRANKCASE OIL PAN for damage or leaks.
122. CHECK TRANSMISSION CASE for damage, loose bolts or oil leaks.
123. CHECK EXHAUST SYSTEM for carbon streaks, see that pipe and muffler are mounted securely.
124. CHECK PROP SHAFT, see that U joint bolts are secure.
125. CHECK JACK SHAFT, see that U joint bolts are secure.
126. CHECK TRANSFER CASE for damage or oil leaks.
127. CHECK PARKING BRAKE DRUM for grease or grime.
128. CHECK UNIVERSAL JOINT for tightness of bolts.
129. CHECK PROP SHAFT for play in shaft or joint.
130. CHECK INTERMEDIATE REAR DIFFERENTIAL, see that bolts are tight, housing not damaged or leaking.
131. CHECK REAR SPRING (L R) for cracked leaves and mounting.
132. CHECK REAR TIRES (Passengers side) for cuts, bruises, or blisters, also check inner walls for fluid leaks
133. CHECK HYDRAULIC LINES (Intermediate & Rear), for signs of leaks.
134. CHECK PROP SHAFT & JOINTS, see that U joint bolts are secure.
135. CHECK REAR DIFFERENTIAL CASE for signs of damage or leaks.
136. CHECK HYDRAULIC LINES for leaks
137. CHECK REAR TIRES (Driver's side) for cuts, bruises, or blisters, also check inner walls for fluid leaks.
138. CHECK AIR TANKS to see if securely mounted also check that drain valves are not damaged.
139. CHECK AIR HYDRAULIC CYLINDER AND MASTER CYLINDER for leaks.
140. CHECK 2 FUEL FILTERS. SECONDARY & FINAL (the front filter is the secondary). If the primary filter (114) was found to be contaminated, drain fuel from the secondary filter into a container and check for water or dirt. Note: Check final fuel filter only when contamination has been found in the secondary fuel filter.